

# FIBER DISTRIBUTION FRAME (FDF) FOR EXCHANGE SIZE 900MM x 2200MM x 300 MM

## 1. General :

1.1 This specification covers the requirements of the fiber distribution frame (FDF) to be supplied to TOT Public Company Limited (TOT) intended to use for cross connection of fiber network in TOT exchange building.

1.2 This FDF shall be designed under indoor environmental condition which used in TOT exchange or building. The primary design consideration of the FDF shall protect the optical fiber from environmental and mechanical stresses. The FDF required as this specification shall be in accordance with figure 1 to 2.

1.3 The fiber patch cord and pigtail used for this FDF specification shall be according to TOT specification specification OES-004-033-01, or latest issue.

1.4 Full details of this following information shall be provided in technical bidding proposal by bidder. Failure in this section the proposal shall be disqualified.

- Product specification in the drawing (See Fig. 1)
- Pictures of fully loaded termination of FDF covering the rack, patching/splicing shelf (showing the wiring of splicing tray, connectorized pigtails, through adaptors and patch cords) and description how to manage or arrange the cables, pigtails and patch cords wiring of FDF. (See Fig.2)

## 2. Feature:

- FDF required in this specification shall at least compose of followings:

- FDF Rack (herein after referred to as the rack)
- Enclosed Rack 19" rack size (482.6 mm)
- Part of optical fiber cable (OFC) routing and OFC loose tube routing (See Fig.2)
- Part of excess patch cord storage and patch cord routing

-Shelf Units :

- Patching/splicing (See Fig. 2)

The FDF proposed shall be designed dimension of FDF. (See Fig.1)

# 19" Rack Exchange & Shelf Unit

## 2.1 FDF Rack:

2.1.1 The rack shall be the metal rack and shall be compliant with ETSI specification ETS 300 119-2. The rack shall be enclosed in cabinet with swing double doors and meet the IP20 protection level according to IEC 60529. Its double doors shall be lockable, transparent and removable re-assembling.

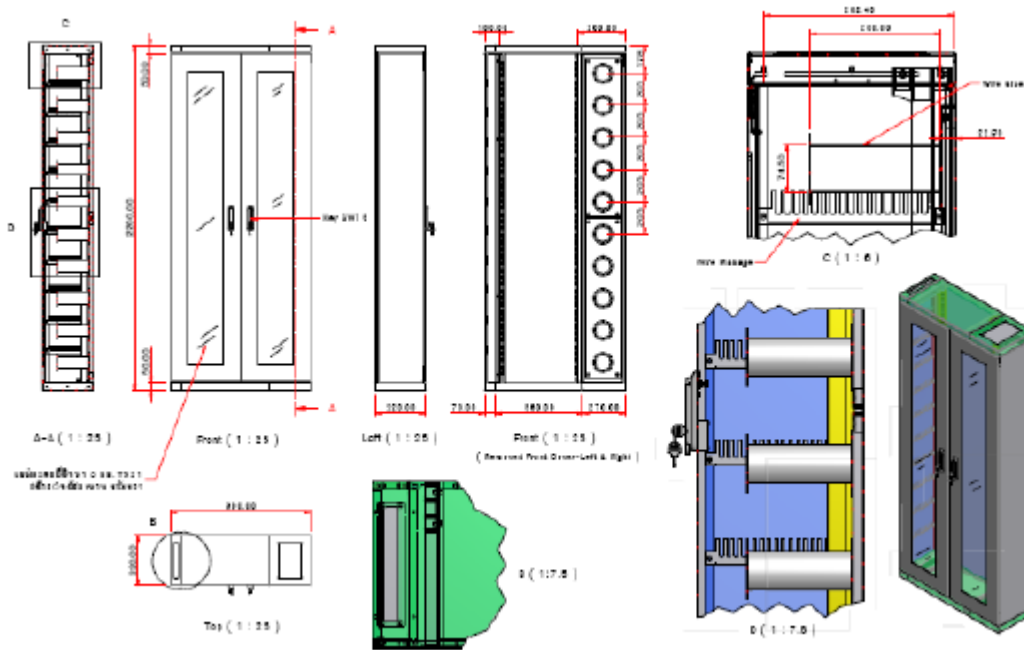

**Fig.1**

2.1.2 The size of the rack shall be as follows :

- Height : 2200 mm.
- Width : 900 mm.
- Depth : 300 mm.
- Material : Steel Sheet
- Color : Light Gray

2.1.3 The rack design shall focus on maximum modularity and flexibility to allow easy on-site assembly and to suite any kind of FDF application.

2.1.4 The rack shall be capable of being installed back to back, side to side or against the wall. No access from the rear or from either side. Since this is the floor type rack and 2.2 meters height for safety reason, the rack shall be provided the mounting hardware to secure and assure the FDF firmly installed with building floor or other available structures.

## 19" Rack Exchange & Shelf Unit

---

2.1.5 The rack shall have complete flexibility in patching management from RHS of the rack to the other, without the need to pre-calculate the individual cable lengths. Storage of excess length of patch cords shall be provided.

2.1.6 The rack shall permit easy access to cables, patch cords and pigtailed during installation, maintenance and upgrade without removal the other existing shelf and without disturbing the systems already in service. The rack shall be only accessible from the FDF front side.

2.1.7 Optical fiber cables and patch cords shall be organized, stored and mechanically protected in the rack. Cables and patch cords shall be able to enter from the top or the bottom of the rack. Provision shall be made for the adequate protection and bend control of cables by using protection tube (see fig. 4) which is flexible construction enables bands to follow wire ways easily, patch cords and pigtailed throughout the rack. A minimum bend radius of 30 mm shall be respected to all bend controls.

2.1.8 All critical bend positions of whole length of patch cord wiring, there shall be bend control devices which have curve surface structure. There are wired management to be used for patch cord as such critical bend position.

2.1.9 Each individual units, its front panel controls and indicators shall be properly identified by number.

2.1.10 The free location in shelf units shall be fitted with dust covers or dummy panels in order to prevent the shelf units from dust.

2.1.11 Protective color coating of the rack shall use powder color coating method with minimum thickness of 50  $\mu\text{m}$ .

2.1.12 The rack (part of OF cable and OFC protection tube routing) shall be designed to allow the accommodation of the incoming/ outgoing OFC up to 12 cables. The incoming/ outgoing cable shall be handled by the break out unit to ensure the cable protection tube/management in between the rack unit to shelf units. The incoming/ outgoing cable shall be fitted into a cable attachment plate with cable clamp. The cable loose tubes shall be distributed by protection tube as cable break out unit device into the flexible tube before get into the shelf unit (splicing/patching shelf). All hardware concerned in this section shall be sufficiently provided to accommodate the in-out OFC as specified.



**Fig. 2**

2.1.13 Standard kit content of the FDF rack shall be as follows:

- 1) Enclosed rack
- 2) Pre-mounted fiber wiring management component for all length of cable, OFC protection tube, patch cord, pigtail as bending control device etc. The fiber wiring management components shall also be sufficiently installed in cable/OFC tube routing and patch cord routing area.
- 3) Identification strips or marking of manufacturer.
- 4) Cable termination system for instance: cable attachment plate with cable clamp, cable break out unit including cable gland and strength member fixations. The termination system component quantity shall also be sufficiently provided as specified.
- 5) protection Spiral wiring band. See Fig. 4.
- 6) Earthing facility: connection of the metal parts to 2 side and a connection point to the building earthing; earthing point shall be provided in the rack, all metallic parts of the rack shall be electrically interconnected with this earthing point.
- 7) Cable shield ground facility.

## 2.2 Shelf Units

The shelf units as defined in this specification shall be required as follows:

( See Fig. 3)

### General Requirement

- 2.2.1 The shelf unit shall be of plug-in type and designed to be mounted in FDF rack (19") as specified in section 2.1.
- 2.2.2 The shelf unit requirement shall be the swing type. The front cover is designed by using metal or acrylic.(optional)
- 2.2.3 Manufacturing process and assembly of all shelf unit components shall use international industry standard. The appearance of product shall be precise, elaborate and none of deformation, sharp edge, crack, scratch, flaw, stain and burr. Its functionality shall be easy for operation.
- 2.2.4 Protective color coating of the shelf unit housing shall use powder color coating method with minimum thickness of 50 µm.
- 2.2.5 The whole patch panel area and front cover at the from side of shelf should be in same background color.(If the cover front is acrylic, the color will be as the acrylic.)
- 2.2.6 The patching/ splicing shelf shall be designed to put in the same shelf unit together, herein after called "patching/ splicing shelf".
- 2.2.7 The patching/ splicing shelf shall provide mechanical protection and storage of pigtailed, fibers, splices, connectors and other passive optical devices in FDF rack.
- 2.2.8 Through adaptor shall be ceramic alignment sleeve. It shall allow to terminate with the same standard connector type of the other manufacturer.
- 2.2.9 The shelf shall be designed to allow the accommodation of the fibers with a minimum bend radius of 30 mm throughout the whole system after installation.
- 2.2.10 Each patching/ splicing shelf unit shall be fully covered with front cover when the shelf is in the extreme close position. Its front cover shall be hinge-able cover inside of cover there shall be the label to note the fiber, routing details related to each fiber adaptor position on patching panel.
- 2.2.11 The splicing organizer tray shall be hinge-able parts and accommodate the single fusion splices up to 12 fibers per organizer tray and support the heat shrink splice protector (sleeve size 60 mm). The tray holder belt shall be also provided.
- 2.2.12 The size of each patching/splicing shelf shall be 3U (maximum) height shelf (3U=5.25"=133.35mm). The bidder shall be able to propose its height lower than 3U but its design shall maintain the spacing interval of

## 19" Rack Exchange & Shelf Unit

though adaptors and fiber capacity per shelf as specified in this specification. The rack enclosure is designed for high density patching application. The rack enclosure is available in 12, 24, 48 and 72 fibers in standard light gray color. The sliding tray has wiring management ball bearing slide hanging which easy to push or pull and also they provide the patching area for patch splice. The splicing tray cab splice 12 fibers/ each try, easy to add the splice tray.



**Fig. 3**

### **Feature:**

- 19" rack mount swing type
- Terminates 12, 24, 48, 60 and 72 fibers.
- Provides easy access for Connector FC, SC, LC, E2000 panel.
- Pullout splicing tray for convenient splicing and field termination.
- Equipped with cable management.
- Removable swing type.
- Material : Steel or Aluminum 2mm with powder coating.
- Size : MM. : 12 & 72 port = 490(W) x 95(H) x 29 (D)

2.2.13 The spacing on the pigtail side between the through adaptor and the splicing tray or fiber management devices, the spacing between those shall be kept the enough space to conveniently access all through adaptors, connectors and pigtails.

2.2.14 In case of FC/UPC connector used,

1. Each patching/ splicing shelf capacity shall be equipped with through adaptor up to maximum 48 fibers (4 rows x 12 columns) and running fiber count as per figure 3.
2. The patching panel shall be designed to be easy-removable to change the through adaptor from FC/ UPC to be SC/ UPC or LC without changing the major part of the shelf unit. (See Fig. 5, 6 )

## 19" Rack Exchange & Shelf Unit

---

3. The patching panel hole for through adaptor shall be the standard D-shape. To be easily accessed for patching and maintenance, the minimum hole spacing of through adaptor measured from center to center in horizontal and vertical interval shall be 25 mm and 19 mm. The minimum spacing below bottom row shall be 24 mm when measured up to center of lowest row hole of through adaptor hole.

### 2.2.15 In case of SC/UPC connector used

1. Each patching/ splicing shelf capacity shall be equipped with through adaptor up to maximum 72 fibers (6 rows x 12 columns or other better allocations) and running fiber count as per figure 6.
2. The patching panel shall be designed for easy operation to access the connector for patching or other maintenance activities. The minimum spacing between through adaptors shall be in accordance with figure 6, except for the vertical spacing shall depend on manufacturer design based on easy – access to all connectors.

### Specific Requirements

2.2.16 Design concept of patching access shall be only the front patching which is classified to be the shelf unit as follows :

- 1) Drawer (slide out) type                      see. Fig. 7, 8, 9
- 2) Swing type    see Fig. 3, 2

### In case of shelf unit with drawer (slide out) type

2.2.17 The shelf unit design in general shall be referred to Fig. 7 for guideline.

The patching/ splicing shelf unit shall consist of chassis with drawer and accommodate the mounting bracket for splicing trays, pigtail bend control devices, patching panel and identification front plate.

The patching/ splicing shelf functionality shall be easy for operation. The drawer tray shall be securely locked by itself with the chassis while the drawer is opened by sliding out to its extreme position in order to prevent the shelf dropping down and also when the drawer tray is closed by sliding into its extreme position the drawer tray shall be securely locked by itself with the chassis.

### In case of shelf unit with swing type.

2.2.18 The shelf unit design in general shall be referred to fig. 2,3 for guideline.

The patching/splicing shelf unit shall at least consist of chassis

## 19" Rack Exchange & Shelf Unit

---

with swing mechanism system, splicing trays, pigtail bend control devices, patching panel and identification front plate.

The patching/splicing shelf functionality shall be easy for operation. The drawer tray shall be securely locked by itself while the drawer to opened by swing out (swing to right side of operator) to its extreme position (90 degree) in order to prevent the shelf moving and also when the drawer tray is closed by sliding into its extreme position the drawer tray shall be securely locked by itself.

The patching/splicing shelf shall be designed to support the full load of its application without obstruction to swing-out and swing- in the patching/splicing shelf. The swing mechanism system shall be installed to strengthen the supporting of shelf-weight and its loads through the product service life.

### 3. Material Requirements

#### 3.1 Rack

- 3.1.1 Material : made of metal material shall be steel or equivalent. Non-metal material shall be allowable.

#### 3.2 Shelf Unit

##### 3.1.2 Patching/ Splicing shelf

1) Drawer : metal material chassis shall be steel, or equivalent and non-metal material shall be allowable.

2) Tray : Polycarbonate, PBT or ABS

3) Through adaptor : Ni (nickel) plated brass or stainless steel (300 series gray or better corrosion resistance material for metal part, and ceramic alignment sleeve.

3.3 All metal hardware and metal part shall be resistant to the corrosive influences they may encounter in normal use.

### 4. Performance Requirements

#### 4.1 Shelf Endurance for drawer type (sliding Type)



## 19" Rack Exchange & Shelf Unit

---

Each patching/splicing shelf (without through adaptor) shall be loaded with 2 kg weight that mounted on the middle position of the shelf and it shall be opened by sliding-out the drawer tray to its extreme position. This drawer tray shall then be closed again by sliding-in the drawer tray into its extreme position until it locks. This sequence shall be repeated 100 cycle times.

After completion the test, the sample shall be examined with naked eyes for damage and the sample shall not appear the deformation, flaws, defects or cracks that could impair functionality.

### 4.2 Shelf Encurance of swing type

Each patching/ splicing shelf (without trough adaptor) shall be loaded with 2 kg weight that mounted on the middle position of the shelf and it shall be opened by swing-out the pivoting part to its extreme position (at 90 degree). This pivoting part shall then be closed again by swing the pivoting part into its extreme position until it locks. The sequence shall be repeated 100 cycle times.

After completion the test, the sample shall be examined with naked eyes for damage and the sample shall not appear the deformation, flaws, defects or cracks that could impair functionality.

### 4.3 Through Adaptor Endurance

Each side of through adaptor shall be terminated and re-terminated with standard connector. Each side of through adaptor shall withstand a minimum mating/ demating 500 times according to IEC-61300-2-2. After test check the appearance and the attenuation and return loss change per connector before and after test shall be less than 0.2 dB and 2 dB respectively when used the 1310, 1550 nm source wavelength.

The appearance : the sample shall be examined with naked eyes for damage and the sample shall not appear the deformation, flaws, defects or cracks that could impair could impair functionality.

## 5. Product Marking and Identification

5.1 All major component of FDF shall be marked with manufacturer name.

5.2 Identification label/ marking/ card/ card holder and record system for fiber routing, fiber count number or other necessary sign or detail in whole FDF area shall be provided.

# 19" Rack Exchange & Shelf Unit

## 6. Ordering Information

TOT CODE	Product Type	Capacity	Packing
	Floor mounted FDF Cabinet	216	
	Floor mounted FDF Cabinet	312	
	Floor mounted FDF Cabinet	528	
	Floor mounted FDF Cabinet	624	
	Drawer patch/splice shelf 19" 3U FC	48	1 set/ box
	Swing patch/ splice shelf 19' 3U FC	48	1 set/ box
	Drawer patch/splice shelf 19" 3U SC	72	1 set/ box
	Swing patch/ splice shelf 19' 3U SC	72	1 set/ box

Note : The other requirement shall be specified on order. For example the floor mounted FDF cabinet 600 fibers is requested by the "FDF" grouping & rehabilitation for 64 exchange"

### SPIRAL WRAPPING BAND:

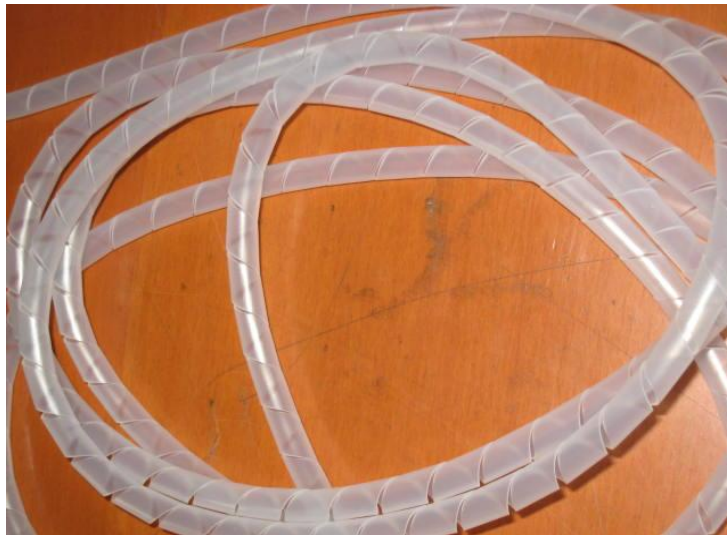

**Fig. 4**

An economical way of cable binding. Easily applied to electric harness cables and wire bundles. Cut-to-fit versatility in convenient roll-form.

## 19" Rack Exchange & Shelf Unit

---

### Features & Benefit

- Material : made from P.E. material. Excellent in insulation and binding strength.
- Color : standard in natural. Black and color available upon request.
- Flexible construction enables bands to follow wire ways easily.
- Durable, reusable with retained spiral strength.
- Fix ends of band with cable ties and spiral wire bundles in clockwise direction to complete words.
- Expand spiral range almost without limit.
- Black color available.

### Size

Item No.	D	D1	W	Wrapping Range(mm.)
SW 15	9	12	13.9	9-65
SW 19	12	15	15	12-75
SW 24	15	19	18.2	15-100

## Patch Panel for Shelf unit 3U SC, LC Connector

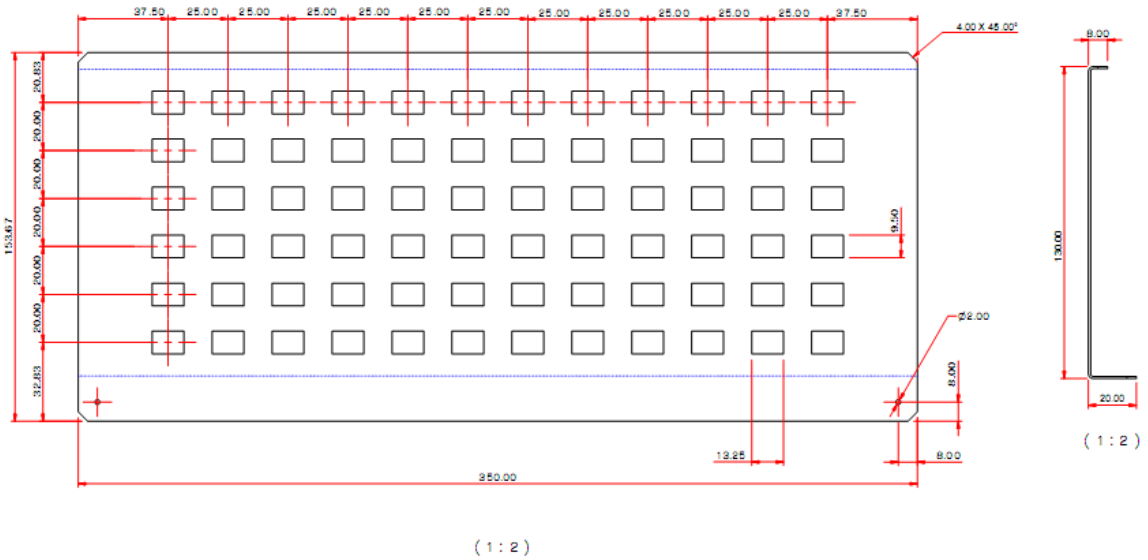

**Fig. 5**

## Patch Panel for Shelf unit 3U FC Connector

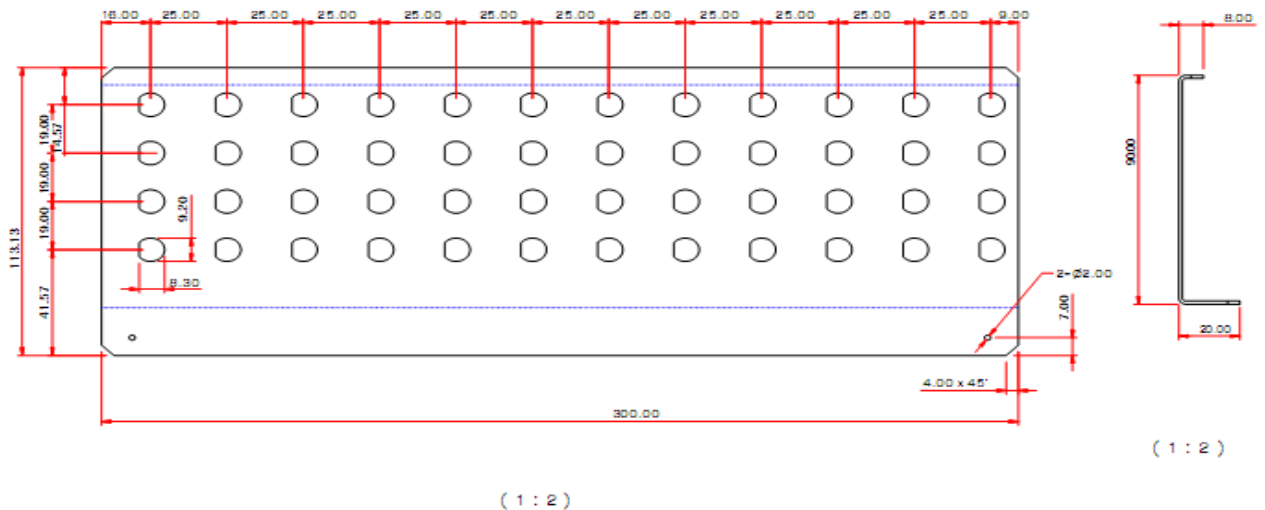

**Fig. 6**

### Feature : Drawer Type

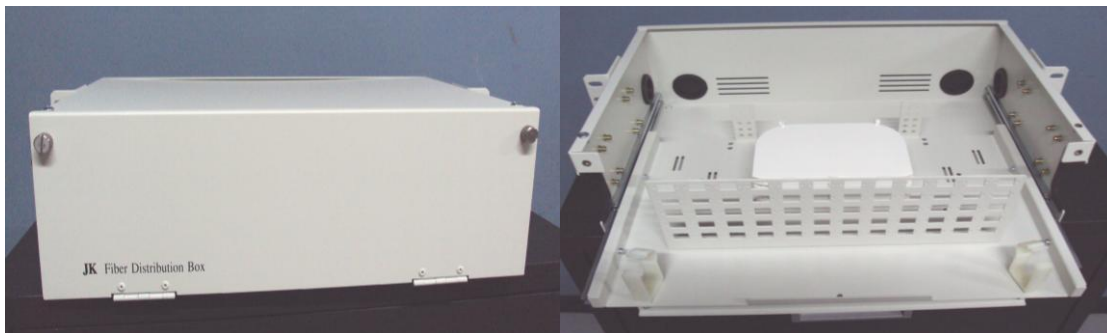
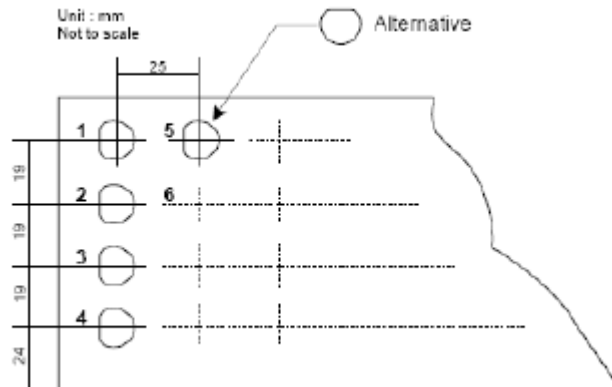

**Fig. 7 typical patching/splicing shelf unit**

- 19" rack mount drawer type
- Terminates 12, 24, 48, 60 and 72 fibers.
- Provides easy access for Connector FC, SC, LC, E2000 panel.
- Pullout splicing tray for convenient splicing and field termination.
- Equipped with cable management.
- Removable drawer type
- Material : Aluminum with power coating.
- size : MM 12 – 72 port = 490 (W) x 135 (H) x 28 (D)

## 19" Rack Exchange & Shelf Unit

This Figure 7 intend to explain the spacing between a patching panel and an identification plate and guide the general design of patching/splicing shelf.



**Fig. 8** Typical FC patch panel of shelf unit (minimum spacing required)

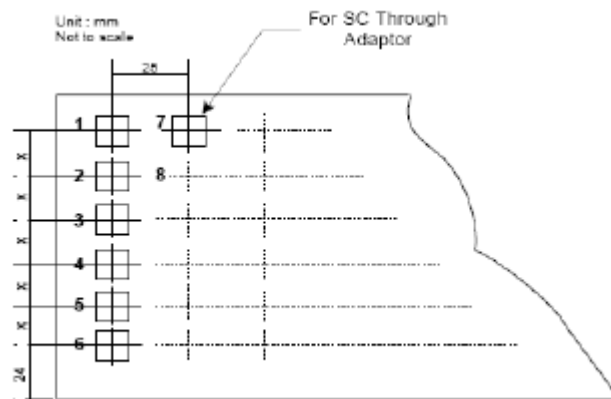

**Fig. 9** Typical SC patch panel of shelf unit (minimum spacing required)

